



EZ-PATH® SERIES 44 FIRE RATED PATHWAY

APPLICATIONS

EZ-PATH® Series 44 Fire Rated Pathway Fire Rated Pathway is designed for easy installation in floors and walls. Tested and approved cable capacities range from 0 to 100% visual fill. EZ-PATH® Series 44 Fire Rated Pathway Fire Rated Pathway when installed with available single wall plates is designed for new cable installations. In these installations, the device does not require mechanical attachment to either the wall or the wall framing and must be installed after the wallboard has been installed. Split floor plates and multi-gang wall and floor brackets permit installation around previously installed cables if so desired. These installations require mechanical attachment to the barrier. A list of available accessories along with their intended use is shown below.

EZ-PATH® Series 44 Fire Rated Pathway Fire Rated Pathway provides exceptional cable capacity. A single unit installed in a wall exceeds the cable carrying capacity of a 6" (152 mm) sleeve utilizing typical putty firestop systems (35% cable loading). Multiple ganged pathways utilizing available wall bracket kits provide additional capacity or segregation of cables by use, type, installer or vendor as desired.

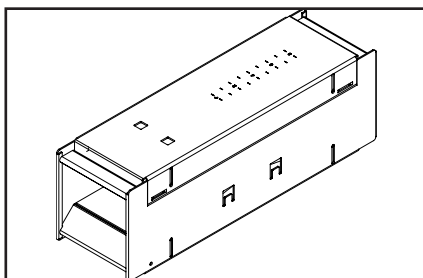
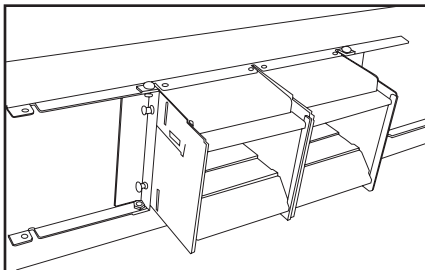

PRODUCT DESCRIPTION

The EZ-PATH® Series 44 Fire Rated Pathway Fire Rated Pathway is a raceway device designed to allow cables to penetrate fire-rated walls and floors without the need for firestopping. This device features a built-in fire and smoke sealing system that automatically adjusts to the amount of cables installed. Once installed in a fire barrier, cables can be easily added or removed at any time without the need to remove or reinstall firestopping materials.

The EZ-PATH® Series 44 Fire Rated Pathway Fire Rated Pathway consists of an enclosed heavy gauge galvanized steel pathway lined with intumescent material engineered for rapid expansion when exposed to fire or high temperatures, quickly sealing the pathway and preventing the passage of flames and smoke. EZ-PATH® Series 44 Fire Rated Pathway is painted safety orange for easy identification. Its compact square profile allows a maximum number of cables to be installed in a relatively small area. The pathway measures approximately 4" x 4 5/8" and is 14" long (102 x 118 x 356 mm).

FEATURES
• Easy to install.
• No firestopping required.
• Firestopped at all stages of use.
• UL Tested - Low Leakage!
• UL Classified for the complete range of its capacity.
• New interlocking design for easy gang installations.
• Permits cable segregation by use, type, vendor.
• More than <i>TWICE</i> the capacity of Standard EZPATH 33.

PERFORMANCE

EZ-Path® is UL Tested and Classified in accordance with ASTM E814 (UL1479). Systems are available for common floor and wall constructions with ratings up to and including 4 hours.

	FILL, VOID OR CAVITY MATERIALS CLASSIFIED BY UNDERWRITERS LABORATORIES INC. ® FOR USE IN THROUGH-PENETRATION FIRESTOP SYSTEMS.	
	SEE UL FIRE RESISTANCE DIRECTORY CLASSIFIED FILL, VOID, OR CAVITY MATERIALS FOR USE IN THROUGH-PENETRATION FIRESTOP SYSTEMS. SEE UL DIRECTORY OF PRODUCTS CERTIFIED FOR CANADA AND UL FIRE RESISTANCE DIRECTORY	

SPECIFICATIONS

All data, video, and communications cable bundles shall utilize an enclosed fire rated pathway device wherever said cables penetrate rated walls. The fire-rated pathway shall contain a built-in fire sealing system sufficient to maintain the hourly fire rating of the barrier being penetrated. The self-contained sealing system shall automatically adjust to the installed cable loading and shall permit cables to be installed, removed, or retrofitted without the need to remove or reinstall firestop materials. The pathway shall be UL Classified and/or FM Systems Approved and tested to the requirements of ASTM E814 (UL1479).

SPECIFIED DIVISIONS

- DIV. 7 07 84 00 Penetration Firestopping
- DIV. 26 26 00 00 Electrical
- DIV. 27 27 00 00 Communications



PHYSICAL PROPERTIES

Dimensions:	4" w x 4 5/8"H x 14" L (102 x 118 x 356 mm)
Shell Composition:	0.059" (1.5 mm) thick galv. steel
Cable Loading Area:	3 1/8" x 3 3/4" (79 x 95 mm)
Allowable Cable Fill:	0 to 100% visual fill
Fire Ratings:	1, 2, 3 or 4 hours
Expansion Begins:	350°F (177°C)
Volume Expansion:	800%
Sample Cable Volume:	244 (Cat 5)
In-Service Temperature:	-10°F (-23°C) - 120°F (49°C)
Storage Temperature:	Less than 120°F (49°C)
Shelf Life:	No Limit

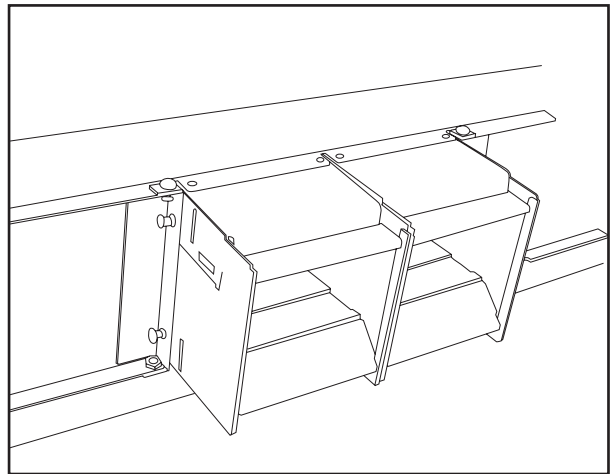

Available Components:

Complete single pathway kits including pathway, wall plates, gaskets, and barrier labeling are available. Pathways and accessories may also be purchased separately as noted below. Suitable fasteners for attaching wall plates may be required and must be purchased separately.

Individual Components & Accessories

Pathway: EZ-Path® 44 Device (EZD44) available as 4 pack.

Single Floor Plate: The single floor plate (EZP144F) is used to install a single pathway in a nominal 6" (152 mm) diameter hole in concrete floors. This plate is split to accommodate existing cabling and may also be used to retrofit cables in walls.

Multi Gang Wall Brackets: Multi gang wall brackets (EZP544W) allow one to five pathways to be installed in walls. Each pathway features a hook and eye locking mechanism that allows multiple pathways to be attached to one another. The multi gang wall brackets are installed around the devices. Multi gang wall brackets are also range-taking so that additional pathways may be added at a later date.

Multi Gang Floor Brackets: Multi gang floor brackets allow a grid of devices to be installed in larger openings in concrete floors. This unique installation consists of brackets and U-shaped channels that lock the devices into place in rows consisting of four pathways. Areas of the opening that will be activated later or saved for future use may be sealed with SpecSeal® Composite Sheet.

Complete Pathway Kits
(Include gasket(s) and barrier labeling)

Single Wall Pathway Kit: EZ-Path® 44 Device, two wall plates (EZDP44).

Single Floor Pathway Kit: EZ-Path® 44 Device, Split Floor Plate (EZDP144FK)

CABLE INSTALLATION

Cables may easily be added or removed at any time without removing or reinstalling the fire seal. Cables may be added individually or in bundles. Wrapping ends with a low-friction tape facilitates cable insertion. Avoid any sharp or exposed conductors that can potentially damage interior pads. A self-adjusting cable throat automatically adjusts to accommodate the cable bundle as it passes through the raceway. Installation of a pulling line will facilitate future cabling additions.

INSTALLATION INSTRUCTIONS

EZ-Path® 44 is designed for use in all common constructions. Single pathways and mounting hardware may be purchased separately or in complete kits. For multi-gang installations, pathways and appropriate mounting hardware must be purchased separately.

Single pathways may be installed in either square or round openings. Ganged pathways are designed to be installed in either square or rectangular openings appropriately sized for the number of units desired (See Installation Instructions). In gypsum board walls, where pathways are ganged, wall plates must be secured to the wall's internal studs.

MAINTENANCE

No maintenance of the pathway is normally required. The interior of the device should be inspected before and after any modifications to the cable bundle. If any damage to the intumescent pads lining the top and bottom of the pathway is found, contact the factory to obtain replacements.

TECHNICAL SERVICE

Technical information including Product Data Sheets, Installation Instructions, applicable UL Classified Systems, Certificates of Conformance, and suggested specifications are available at the company's web site (www.stifirestop.com). For all other information, contact the manufacturer directly by dialing (800) 992-1180.

PRECAUTIONARY INFORMATION

The use of this device is subject to local, regional and national codes. Consult the local Building Code Official or Authority Having Jurisdiction regarding any regional or local requirements that might influence the selection or use of this product.

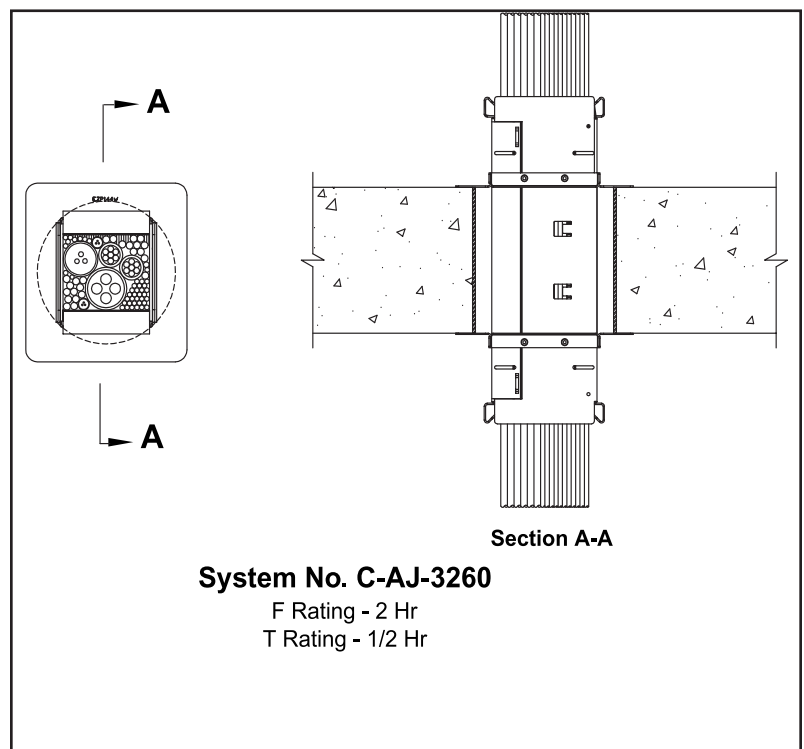
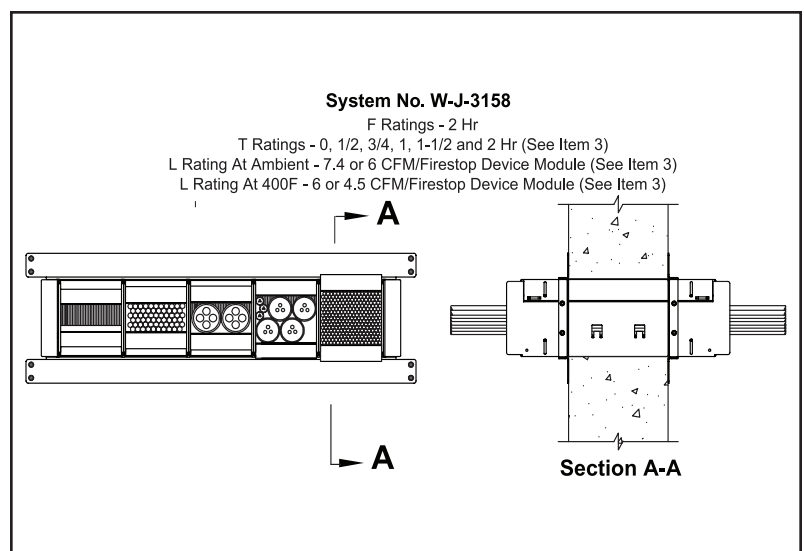
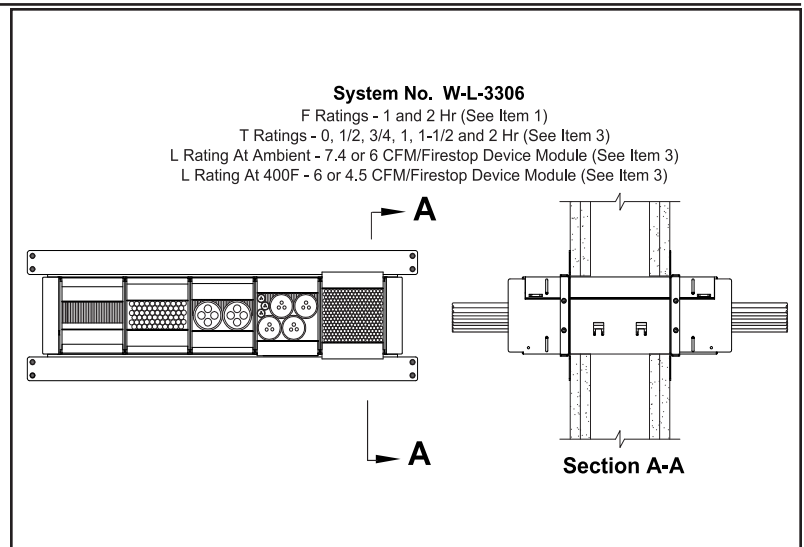

AVAILABILITY

See Table A - Ordering Information. EZ-PATH® Fire-Rated Pathway Products are available from designated authorized STI distributors. Consult the factory or visit the web site (www.stifirestop.com) for the names and locations of the nearest sales representatives or distributors.

TABLE A: ORDERING INFORMATION

Catalog Number	Description
EZDP44	EZPATH 44 Fire-Rated Pathway Kit Full Kit with device, wall plates & labels
EZDP144FK	EZPATH 44 Fire-Rated Pathway Floor Kit Full Kit with device, floor plate & labels
EZP144W	One Pair (2) 44 single wall plate pack
EZP544W	44 5 gang wall plate brackets
EZP144F	44 Split floor plate pack
EZD44	Series 44 device
EZDG444	One (1) Included - Pathway Module (Four Pathways)
EZDG844	Two (2) Included - Pathway Module (Four Pathways)
EZDG1644	Four (4) Included Pathway Module (Four Pathways)
EZG844	Two (2) Purchase Separately - Pathway Module (Four Pathways)
EZG1644	Four (4) Purchase Separately - Pathway Module (Four Pathways)



CITY OF NEW YORK MEA 369-02-M

Additional EZ-PATH® Products...

Pathways

Easy installation and cable changes without firestopping! EZ-PATH is available in 3 sizes to accommodate your cabling needs. From MINI applications that hold up to 15 Cat. 6 cables, to our Standard 33 size that accommodates greater cable loading than a conventional 4" sleeve, EZ-PATH is the code compliant solution designed to facilitate the installation of cables through fire-rated walls and floors.

Extension Module - Increase the pathway length for thicker walls by attaching the module to the end of a series 33 pathway. Extensions work with all other accessories in the 33 series.

Mounting Plates

Mounting plates are available for the standard 33 series in single, double, triple, four -and- seven gang installations. Additionally, plates are available for floor applications and applications where pathways are installed within 4" sleeves or conduits. Visit our website at www.stifirestop.com for complete accessories listing.

SSB Firestop Pillows

Durable, monolithic pillows for installations requiring quick and easy retrofitting.

CS Composite Sheet

Firestop panels designed to seal medium to large size openings with a variety of different penetrants in fire-rated floors and walls.

IMPORTANT NOTICE: All statements, technical information, and recommendations contained herein are based upon testing believed to be reliable, but the accuracy and completeness thereof is not guaranteed.

WARRANTY

Specified Technologies Inc. manufactures its goods in a manner to be free of defects. Should any defect occur in its goods (within one year), Specified Technologies Inc., upon prompt notification, will at its option, exchange or repair the goods or refund the purchase price.

LIMITATIONS AND EXCLUSIONS:

THIS WARRANTY IS IN LIEU OF ALL OTHER REPRESENTATIONS EXPRESSED OR IMPLIED (INCLUDING THE IMPLIED WARRANTIES OF MERCHANTABILITY OR FITNESS FOR USE) AND UNDER NO CIRCUMSTANCES SHALL SPECIFIED TECHNOLOGIES INC. BE RESPONSIBLE FOR ANY INCIDENTAL OR CONSEQUENTIAL PROPERTY DAMAGE OR LOSSES. PRIOR TO USE, THE USER SHALL DETERMINE THE SUITABILITY OF THE PRODUCT FOR ITS INTENDED USE, AND THE USER ASSUMES ALL RISKS AND LIABILITY FOR SUBSEQUENT USE.

No statement or recommendation not contained herein shall have any force or effect unless in an agreement signed by officers of seller and manufacturer.

MADE IN THE USA – COPYRIGHT © 2008 SPECIFIED TECHNOLOGIES, INC.



Specified Technologies Inc. • 200 Evans Way, Somerville NJ 08876 • Phone: 800.992.1180 • Fax: 908.526.9623

