

Firestop Collars

1. PRODUCT DESCRIPTION

The SpecSeal® Firestop Collar is a factory-manufactured device designed to protect plastic pipes penetrating fire-rated walls and floors. Utilizing a heavy gauge galvanized metal collar to house a molded intumescent insert, the SpecSeal® Collar is specifically sized to fit 1-1/2", 2", 3", 4", and 6" trade sized pipes.

This product utilizes STI's patented two-stage intumescent technology, providing a very responsive and highly directionalized expansion. Expansion is extremely fast, providing quick closure for burning combustible pipes.

When exposed to temperatures in excess of 250°F (121° C), the SpecSeal® Collar's molded insert begins to expand (intumesce) rapidly to form a dense, highly insulative char. Its free expansion ranges from 16-24 times original (pre-expanded) volume. Expansion continues up to 1,000° F.

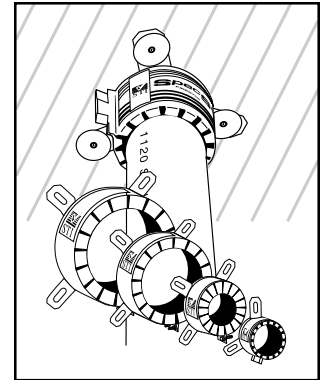

2. APPLICATIONS

SpecSeal® Collars are used to protect a variety of plastic pipes including PVC, PVC Foam Core (ccPVC), CPVC, ABS, ABS Foam Core (ccABS), and FR Polypropylene in both vented (DWV) and closed (electrical conduit and water supply) installations.

SpecSeal® Collars are suitable for use in all common forms of construction including concrete floors, concrete over steel deck, concrete walls, concrete block walls, gypsum board walls, and wood floor assemblies.

SpecSeal® Collars are used alone or in combination with other SpecSeal® products to protect a wide variety of nonmetallic pipe penetrations either individually or in combination with other types of penetrants.

3. PHYSICAL PROPERTIES

See Table A. This material is extremely stable. Long term aging studies indicate no significant loss of physical properties nor significant change in expansion properties after elevated temperature, humidity, and immersion testing. Consult factory for additional information.

4. PERFORMANCE

SpecSeal® Collars are the basis for systems that meet the exacting criteria of ASTM E814 (UL1479). Systems have been tested for all common forms of construction and most common penetrants with ratings up to three hours.

STI designed firestop systems are engineered to maximize the fire resistance of the seal by not only sealing off the spread of fire and hot gasses but also by minimizing the amount of heat conducted through the assembly. Thus all systems have been designed to provide T Ratings capable of matching the rating of the wall or floor assembly (where possible). Consult factory for information not available in UL Fire Resistance Directory as of this printing.

NOTICE: The use of this product may be regulated by regional or local codes. CONSULT THE LOCAL AUTHORITY HAVING JURISDICTION.



THROUGH-PENETRATION
FIRESTOP DEVICE CLASSIFIED BY
UNDERWRITERS LABORATORIES INC. ®
8L98 SEE UL FIRE RESISTANCE DIRECTORY

FEATURES

- **Rapid Expansion:** Closes off burning penetrants faster.
- **High Volume Char:** Expands over 20 times!
- **Water-Resistant:** No soluble or hygroscopic ingredients.
- **Economical:** Factory assembly reduces field labor!
- **Easy Installation:** No guess work.
- **Approved** for a wide variety of pipes and constructions.

5. SPECIFICATIONS

The firestop system shall be a factory assembled firestop collar utilizing a molded two-stage, flexible intumescent insert. The intumescent insert shall provide a minimum of 15X free expansion and shall contain no water soluble expansion ingredients. The specified material shall be approved for a wide range of applications including PVC, CPVC, ABS, ABS Foam Core, and FRPP pipes when used by itself or in combination with other products from the same manufacturer. The collar shall be UL Classified and/or FM Systems Approved and tested to the requirements of ASTM E814 (UL1479).

SPECIFIED DIVISIONS

DIV. 7	07840	Through-Penetration Firestopping
DIV. 13	13900	Special Construction Fire Suppression & Supervisory Systems
DIV. 15	15250	Mechanical Insulation – Fire Protection
DIV. 16	16050	Basic Electrical Materials & Methods

**For the latest Product and System Information, Call
STI'S FACTS-ON-DEMAND automated information attendant
system by dialing toll-free (888)526-6800!**

Table A: PHYSICAL PROPERTIES

Available Sizes	1.5" thru 6"
Shell Construction	22 Gauge Gal. Steel
Intumescent Insert	Molded one piece.
Expansion Begins	250° F (1st stage) 350° F (2nd stage)
Volume Expansion	16 to 24x (free expansion)
In-Service Temp.	≤ 130° F.
Oven Aging	No Change (60°C)*
Humidity Exposure	No Change (60°C, 98% R.H.)*

* Evaluation of physical properties and total expansion.

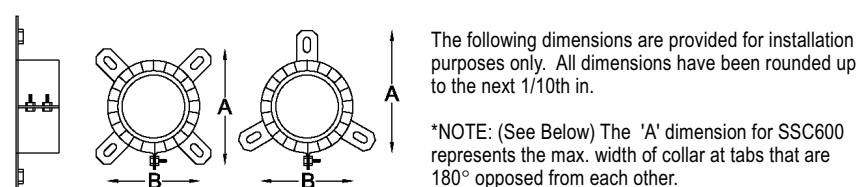
Table B: COLLAR DIMENSIONS

The following dimensions are provided for installation purposes only. All dimensions have been rounded up to the next 1/10th in.

*NOTE: (See Below) The 'A' dimension for SSC600 represents the max. width of collar at tabs that are 180° opposed from each other.

CAT NO:	SSC151	SSC202	SSC301	SSC400	SSC600
Trade Size	1-1/2"	2"	3"	4"	6"
A	4.2"	4.5"	5.6"	7.1"	11.2"*
B	2.8"	3.2"	4.5"	6.2"	8.3"
C	1.5"	1.5"	2"	2"	4"

6. INSTALLATION

GENERAL: The installation of this product requires the application of a smoke seal utilizing SpecSeal® Series SSS Sealant and suitable mechanical fasteners for attachment to the floor or wall surface. Sealant and floor or wall attachment hardware must be purchased separately. Any fasteners required to close the collar around the pipe itself are included in the collar package.

SYSTEM SELECTION: Proper methods and materials are critical to firestopping. A number of methods have been developed to suit a wide variety of firestopping applications. Tables B and C have been provided to assist in determining of systems suitable for various applications. Furthermore, many installations have been illustrated throughout this data sheet and new systems are continually being tested. For more information consult your local distributor, sales rep. or call STI toll free at (800) 992-1180.

SMOKE SEALING: Smoke sealing is a vital step in the firestopping process. Since proper smoke seal design will vary from one type of construction to another, STI has elected to require a separate sealing step. A separate seal provides for abnormalities in floor or wall surfaces (such as blow-outs in core drilled holes), variations in annular space, and prevents the passage of smoke produced by deterioration of the pipe itself within the wall or floor cavity. This seal in floor applications, also seals against water leakage into the floor cavity in plumbing or mechanical installations. For additional information on this topic, request "Firestopping Plastic Pipes," SpecSeal® Technology Update.

Smoke seals should be installed at the top and bottom surfaces of floor/ceiling assemblies. In solid concrete floors, a single seal may be installed at the lower surface. It is strongly recommended however, that an additional seal be caulked at the top side to seal against smoke generated within the floor cavity itself. Smoke seals are required at both sides of wood floor assemblies and hollow wall cavities.

Apply sealant to a clean surface, free of dirt, oil, rust, or scale. Caulk annulus shut using a nominal 3/8" bead. Sealant may be smoothed out or the collar may be set directly into the wet sealant.

NOTE: Collars installed around pipes poured directly into SpecSeal® Mortar do not require this sealing step.

FASTENERS: Always use the correct type of fastener. The fastener types used in product testing are shown in Table C. All fasteners should be steel (lead or plastic fasteners are unsuitable and should not be used). 1 1/4" or 1 1/2" fender washers are used in conjunction with all wall or floor fasteners. All fasteners should be installed as per the recommendations of the manufacturer.

CONCRETE: Expanding wedge type anchors (1/4" x 1 3/4") are recommended. Powder activated fasteners may be used at the discretion of the installer and are subject to the recommendations of the fastener manufacturer.

GYPSUM WALLBOARD: Toggle bolts or molly-type expanding anchors are suitable for collar attachment.

GYPSUM BOARD-WOOD FLOOR FLOOR/CEILINGASSEMBLIES: Toggle bolts are suggested for gypsum wallboard ceiling attachment. Collars mounted internally and fastened to wood may use standard #8 x 1/2" round head wood screws for attachment.

Table C: APPLICATION INFORMATION

DESCRIPTION FLOOR/WALL CONSTRUCT.	PIPE SIZE	ATTACHMENT HARDWARE*	ANNULAR SPACE	UL SYS. NO.	HOURLY RATING	FIG.
Concrete Floor						
PVC, CPVC, ABS, PVDF	≤ 4"	1	≤ 1/2"	CAJ-2038	≤ 3	3, 4
FR PP	≤ 4"	1	≤ 1/2"	CAJ-2045	≤ 2	3, 4
PVC, CPVC, FR PP, ABS	6"	1	≤ 1/2"	CAJ-2089	≤ 3	3
Concrete or Block Wall						
PVC, CPVC, ABS, PVDF	≤ 4"	1	≤ 1/2"	CAJ-2038	≤ 3	5, 6
FR PP	≤ 4"	1	≤ 1/2"	CAJ-2045	≤ 2	5, 6
PVC, CPVC, FR PP, ABS	6"	1	≤ 1/2"	CAJ-2089	≤ 3	5
Gypsum Wallboard						
PVC, CPVC, ABS, FR PP, PVDF	≤ 4"	2 or 3	≤ 1/2"	WL-2029	≤ 2	7
PVC, CPVC, FR PP, ABS	6"	2 or 3	≤ 1/2"	WL-2074	≤ 2	7
Wood Floor Drain, Waste, Vent Stack						
PVC, ABS	≤ 4"	4	≤ 1/2"	FC-2034, 2035	1	
Wood Floor Single Collar						
PVC, CPVC	≤ 4"	3	≤ 1/2"	FC-2020	≤ 2	8
Wood Floor Double Collar						
PVC, CPVC	≤ 4"	3 & 4	≤ 1/2"	FC-2021	≤ 2	9

* ATTACHMENT HARDWARE CODE:

(Fender washers are recommended and often required)

1 = Concrete wedge anchors, 2 = Steel molly-type fasteners

3 = 3/16" Toggle bolts, 4 = #8 X 1/2" round head wood screws.

NOTE: PVC & ABS are approved for solid or cellular core piping up to four inch trade size.

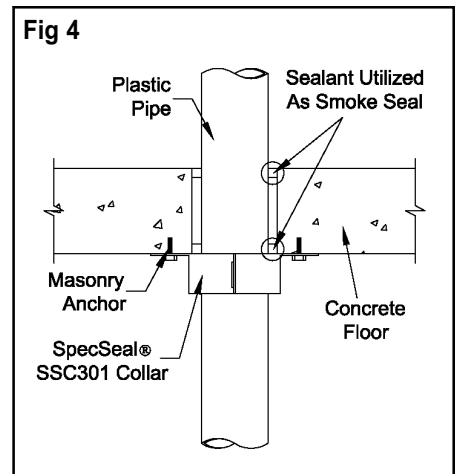
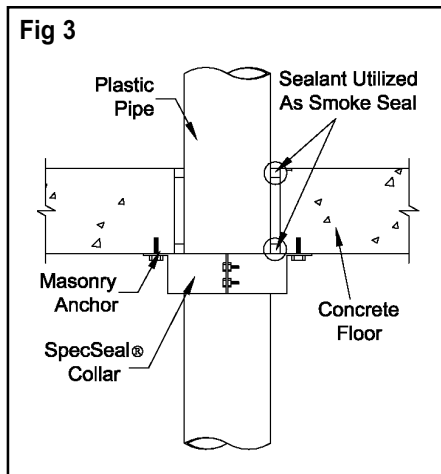
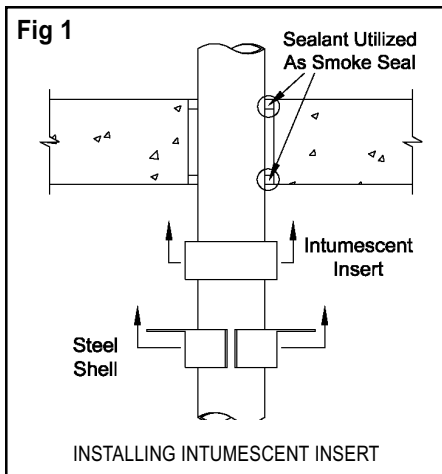

INSTALLATION PROCEDURE:

1. Apply smoke seal (see above).
2. To install collar around pipe: Flex intumescent insert, followed by the outer steel shell around pipe (See Fig. 1). Close steel shell around insert and fasten by crimping tab closure for SSC151, 202, and 301 models (see Fig. 2), or by bolting shell together using supplied fasteners (SSC400 & 600 models). Snug fasteners sufficiently to allow collar to slide.
3. Slide collar to wall or floor surface and mark anchor holes for drilling.
4. Drill holes and install fasteners as per the requirements of the fastener manufacturer. Place 1 1/4" fender washers of the appropriate diameter over fastener at collar mounting tabs and tighten anchors fully.
5. Recheck and tighten shell bolts fully to complete installation.

7. MAINTENANCE

INSPECTION: Installations should be inspected periodically for subsequent damage. Any damage should be repaired using SpecSeal® products per the original approved design.

RETROFIT: When adding or removing penetrants, care should be taken to minimize damage to the seal. Reseal using SpecSeal® products per the approved design.

NOTE: New penetrants of a different nature than the original design may require a totally new firestop design or extensive modifications to the existing design. Reseal all openings as per the requirements of the new design.

8. TECHNICAL SERVICE

Specified Technologies Inc. provides toll free technical support to assist in product selection and appropriate installation design. Design System Drawings suitable for submittal or specification purposes are available on request.

9. PRECAUTIONARY INFORMATION

Consult Material Safety Data Sheet for additional information on the safe handling and disposal of this material. Wash areas of skin contact with soap and water. Avoid contact with eyes.

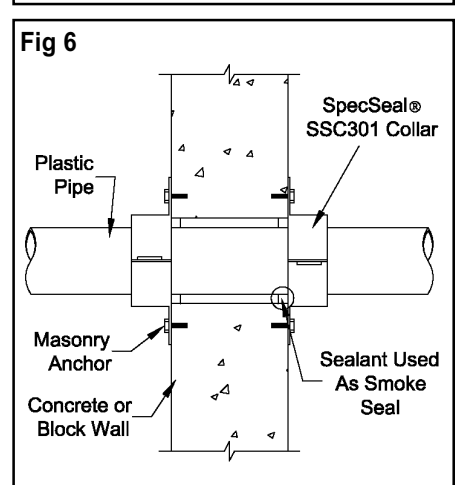
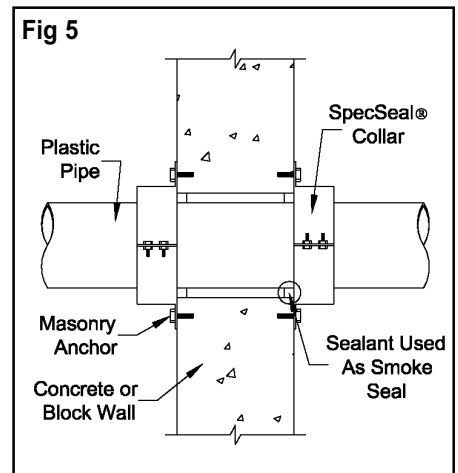
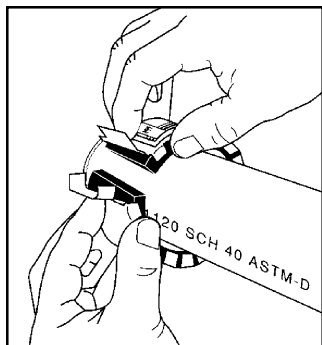
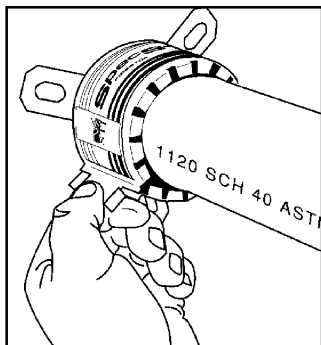

Fig 2: SSC151, 202 & 301 CRIMP CLOSURE & MOUNTING



1. Wrap collar around pipe.



2. Press tab into slot.

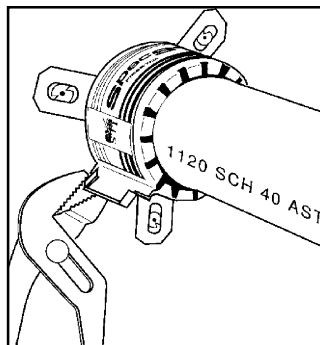

3. Crimp tabs closed using pliers.

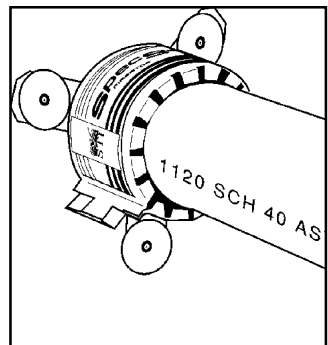

4. Fasten to wall or floor.

Fig 7

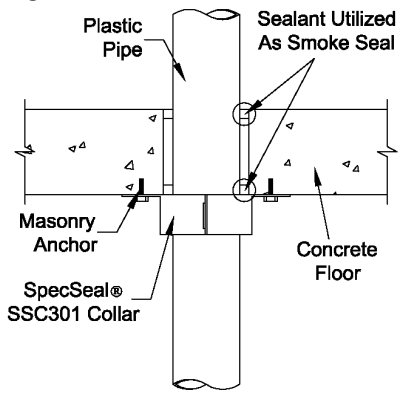

Fig 8

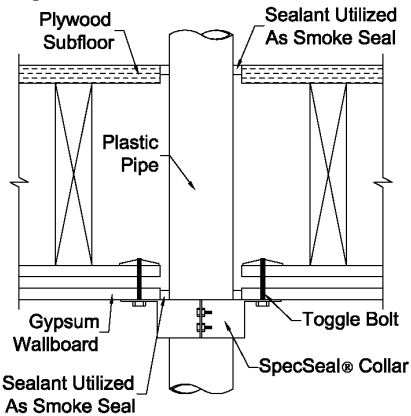
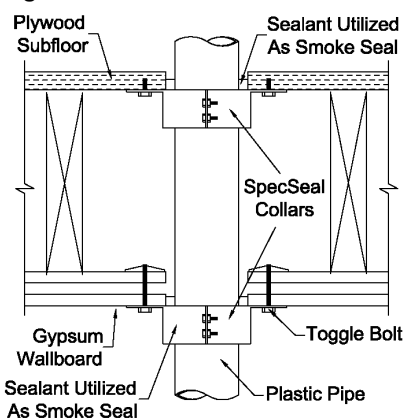

Fig 9



10. AVAILABILITY

SpecSeal® Firestop Collars are available from authorized STI distributors nationwide. Consult factory for the names and locations of the nearest sales representatives or distributors. Available packages and additional SpecSeal® Products are listed in Table D.

Table D: ORDERING INFORMATION

Cat. No.	Name	Description
SSC151	Firestop Collar	Fits 1-1/2" Trade size pipes. Utilizes crimp closure.
SSC202	Firestop Collar	Fits 2" Trade size pipes. Utilizes crimp closure.
SSC301	Firestop Collar	Fits 3" Trade size pipes. Utilizes crimp closure.
SSC400	Firestop Collar	Fits 4" Trade size pipes. Utilizes bolt closure, bolts included.
SSC600	Firestop Collar	Fits 6" Trade size pipes. Utilizes bolt closure, bolts included.



Additional SpecSeal Products...

- Series SSS Sealant** The industry's most versatile sealant provides the firestopping solutions for a wide range of combustible and noncombustible applications. Water-based intumescent sealant expands up to 8x!
- Series LC Sealant** An economical latex firestop sealant for noncombustible applications. Non-halogenated, easy clean up, flexible, water-resistant!
- SSP Firestop Putty** Available both in bar form and in pads, putty provides easy retrofit for through-penetrations and economical protection for electrical boxes.
- SSB Firestop Pillows** Durable, monolithic pillows for installations requiring quick and easy retrofitting. Systems designed for pipes, cables and cable tray in all types of construction!
- Firestop Mortar** Lightweight, versatile and economical! The best choice for large or complex installations.
- Pensil® Silicones** Sealants and foam for through-penetrations and construction joints. Unexcelled aging characteristics and flexibility.
- Intumescent Wrap Strips** Two grades of intumescent wrap strips provide an unmatched combination of flexibility, economy, and expansion (up to 30X). Systems for plastic pipes including FR Polypropylene up to 8" trade size!
- Elastomeric Joint Seals** New economical products for sealing construction joints. Choose caulk or spray applied products tested to UL2079.

CITY OF NEW YORK MEA 307-92M

Important Notice: All statements, technical information, and recommendations contained herein are based upon testing believed to be reliable, but the accuracy and completeness thereof is not guaranteed.

WARRANTY: Specified Technologies Inc. manufactures its goods in a manner to be free of defects. Should any defect occur in its goods (within one year), Specified Technologies Inc., upon prompt notification, will at its option, exchange or repair the goods or refund the purchase price.

Limitations and Exclusions: THIS WARRANTY IS IN LIEU OF ALL OTHER REPRESENTATIONS EXPRESSED OR IMPLIED (INCLUDING THE IMPLIED WARRANTIES OF MERCHANTABILITY OR FITNESS FOR USE) AND UNDER NO CIRCUMSTANCES SHALL SPECIFIED TECHNOLOGIES INC. BE RESPONSIBLE FOR ANY INCIDENTAL OR CONSEQUENTIAL PROPERTY DAMAGE OR LOSSES. PRIOR TO USE, THE USER SHALL DETERMINE THE SUITABILITY OF THE PRODUCT FOR ITS INTENDED USE, AND THE USER ASSUMES ALL RISKS AND LIABILITY FOR SUBSEQUENT USE.

No statement or recommendation not contained herein shall have any force or effect unless in an agreement signed by officers of seller and manufacturer.

MADE IN THE USA – COPYRIGHT © 2000 SPECIFIED TECHNOLOGIES, INC.



200 Evans Way • Somerville, NJ 08876
 Phone: (800) 992-1180 • Fax: (908) 526-9623
 Facts-On-Demand: (888) 526-6800
 STI on the WEB: www.stifirestop.com